



Vestil Manufacturing Corp.

A company dedicated to solving loading dock and material handling problems since 1955.

2999 North Wayne Street, P.O. Box 507, Angola, IN 46703

Telephone: (260) 665-7586 -or- Toll Free: (800) 348-0868

Fax: (260) 665-1339

<http://www.vestil.com/> email: info@vestil.com

EHLTX-Series Low Profile Electric Hydraulic Scissors Lift Table Instruction Manual



Model EHLTX-3-39

Receiving instructions:

After delivery, remove the packaging from the product. Inspect the product to determine whether it sustained damage during transport. If damage is discovered, record a complete description of it on the bill of lading and file a claim with the carrier immediately! If the product is undamaged, discard the packaging.

NOTE:

The end user is solely responsible for confirming that product design, use, and maintenance comply with laws, regulations, codes, and mandatory standards applied where the product is used.

Replacement Parts and Technical Assistance:

If you have questions that are not addressed in these instructions, or to order replacement parts, labels, and accessories, call (260) 665-7586 and ask for the Service and Parts Department. You can also reach Service and Parts online at http://www.vestilmfg.com/parts_info.htm.

Electronic Copies of Instruction Manuals:

Additional copies of this instruction manual may be downloaded from <https://www.vestil.com/page-manuals.php>.

Table of Contents

Signal words	2
Hazards	2
Model number and capacity	3
Exploded part views and Bills of Material	4
Electrical and hydraulic system diagrams	12
Installation instructions	19
Accessories	23
Record of satisfactory condition	24
Operation instructions	25
Inspection and maintenance	26
Troubleshooting	29
Labeling diagram	31
Limited warranty	32

SIGNAL WORDS

This manual uses SIGNAL WORDS to direct the reader's attention to important safety-related messages. These messages describe uses of the product that could result in personal injury or property damage. Each signal word corresponds to a specific hazard level. The following are definitions of signal words that might appear in this manual.



Identifies a hazardous situation which, if not avoided, WILL result in DEATH or SERIOUS INJURY. Use of this signal word is limited to the most extreme situations.



Identifies a hazardous situation which, if not avoided, COULD result in DEATH or SERIOUS INJURY.



Indicates a hazardous situation which, if not avoided, COULD result in MINOR or MODERATE injury.



Identifies practices likely to result in product/property damage, such as operation that might damage the product.

HAZARDS

Vestil Manufacturing strives to identify all foreseeable hazards associated with the use of its products. However, material handling is dangerous and no manual can address every risk. The end user is ultimately responsible for exercising sound judgment at all times in the use of this product.



Improper or careless operation of this device might result in serious personal injuries.

- **Read and understand this entire manual before installing, assembling, using or servicing this lift table.** Keep this manual in a location known to persons who use the lift table. Read the manual whenever necessary to refresh your understanding of proper use, inspection, and maintenance procedures. **Failure to read and understand this owner's manual before using or servicing the lift table constitutes a misuse of the product.**
- The Electric Hydraulic Scissors Lift Table presents pinch point and hydraulic pressure hazards to the user and bystanders. ALWAYS follow these instructions to avoid injury.
- The lift table is intended for use on a level concrete surface. DO NOT use a lift table that has not been anchored to a level concrete surface. See installation instructions starting on page [19](#).

- The lift table shall be installed only by trained and qualified personnel with access to appropriate equipment. Electrical connections shall be performed by a qualified electrician.
- DO NOT load the table beyond its lift rated capacity. Handle only stable and safely arranged loads within the maximum capacity of the lift. The lift capacity can be found on the nameplate on the hinged end of the platform.
- ALWAYS use care to center and distribute the load evenly on the lift platform.
- DO NOT attempt to lift an overhanging or cantilever load.
- DO watch the load when the lift table is in operation.
- ALWAYS keep clear of the lift table while it is moving.
- DO NOT place hands or feet under the platform. DO NOT put any body part in the scissor mechanism.
- DO NOT use this lift table to raise personnel.
- DO NOT store objects under the platform.
- DO NOT use the lift table if any damage is observed, or unusual noises heard.
- DO NOT operate a lift table with its perimeter toe guard removed, disabled, or inoperable. An optional accordion skirt may be installed in above-ground installations.
- DO ensure that all information, safety, and warning labels remain in place and are legible.
- DO remove any load from the lift table before servicing the lift table or its hydraulic power unit. DO completely lower the platform, or use the attached maintenance prop bars to support the platform, before servicing this product.
- If oil is needed, DO use an anti-wear hydraulic oil with a viscosity grade of 150 SUS at 100°F (ISO 32 cSt @ 40°C) or Dexron non-synthetic transmission fluid. DO NOT use brake fluid or jack oils in the hydraulic system.
- Contact the manufacturer for SDS (Safety Data Sheet) information.
- Maintenance and repairs are to be done only by personnel qualified to perform the required work. Consideration will not be given for warranty repair charges without prior written authorization by the manufacturer.
- DO NOT perform any modifications to the lift table without the manufacturer's approval. Failure to receive authorization for changes to the equipment automatically voids the warranty.

NOTICE

Proper use and maintenance are essential for this product to function properly.

- Always use this product in accordance with the instructions in this manual.
- Periodically lubricate pivot points with bearing grease.
- Keep the product dry and clean at all times. Always use this product indoors.
- Use only factory-approved replacement parts. Contact Vestil Manufacturing to order replacement or spare parts.
- Contact the manufacturer for SDS information.

MODEL NUMBER AND CAPACITY

The lift table model number, serial number and capacities are printed on the nameplate, found on the hinged side of the platform. Refer to the product catalog of the factory for further information. Include the model and serial numbers in all correspondence with your dealer or the factory.

The load capacity rating as printed on the nameplate of your lift table designates its net capacity. The addition of ancillary equipment to the lift table will necessitate a lowering of the load capacity. The lift table's load capacity must never be exceeded, as permanent damage or personal injury may result.

EXPLODED PART VIEWS AND BILLS OF MATERIAL

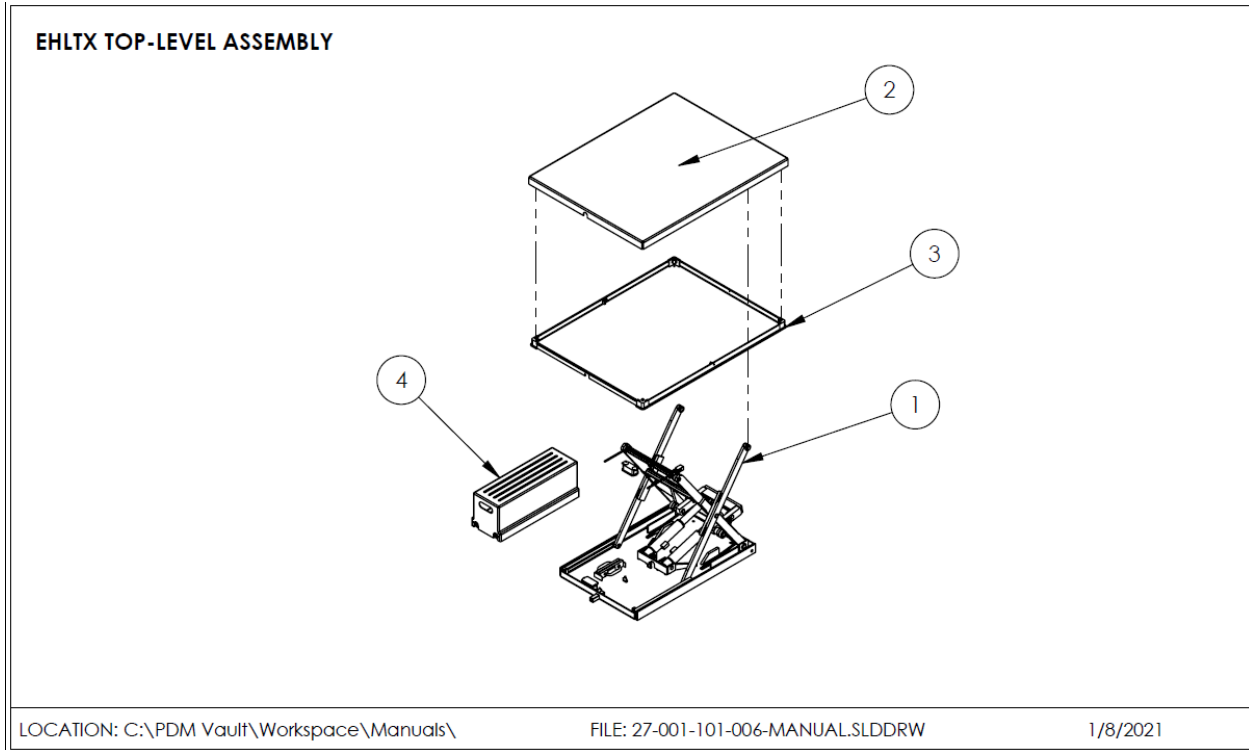

EHLTX Top-Level Bill of Materials

ITEM	DESCRIPTION
1	BASE ASSEMBLY
2	PLATFORM
3	PERIMETER TOE GUARD ASSEMBLY
4	POWER UNIT

** See separate illustrations and tables for detailed parts lists*

MASTER EXPLODED VIEW
EHLTX-####-1-39 AND EHLTX-####-2-39

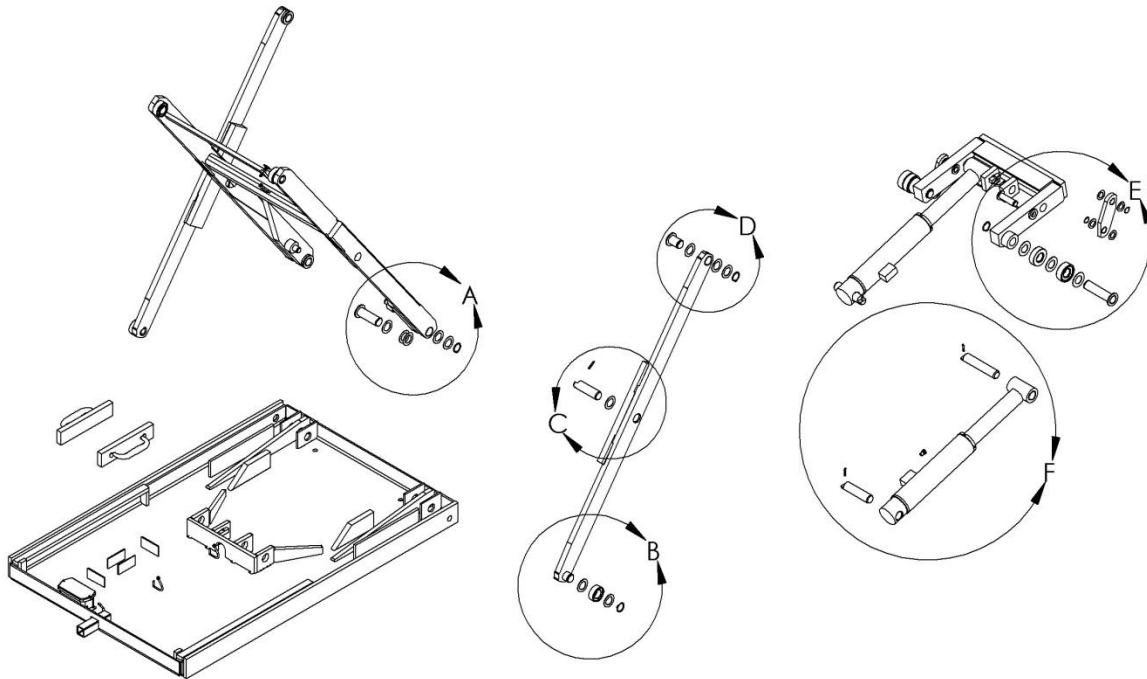

LOCATION: C:\PDM Vault\Archive\27\

FILE: 27-001-101-002.SLDDRW

4/2/2020

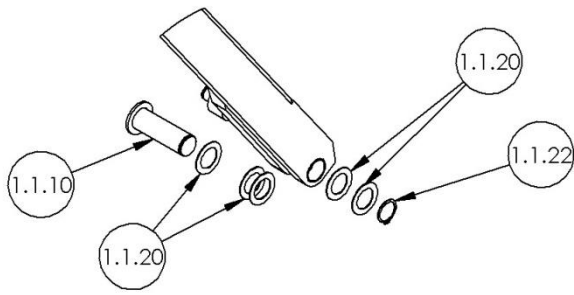

DETAIL A

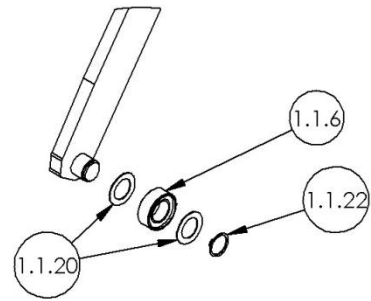

DETAIL B

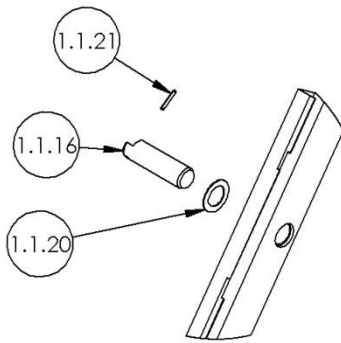

DETAIL C

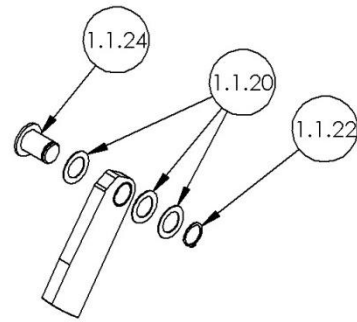

DETAIL D

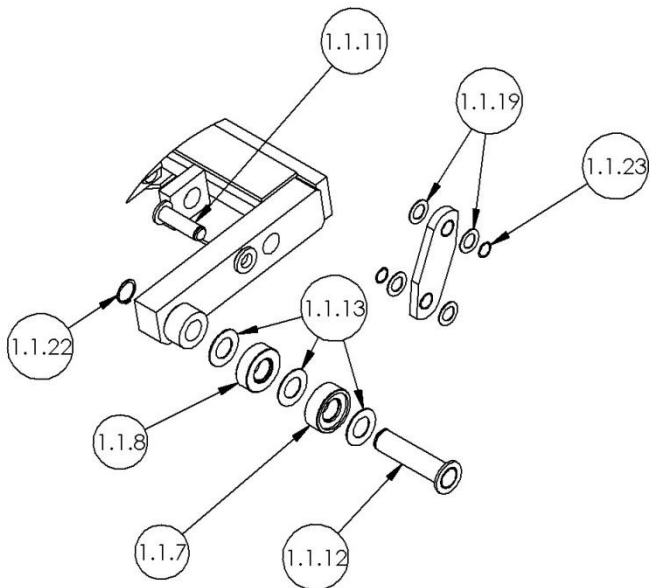

DETAIL E

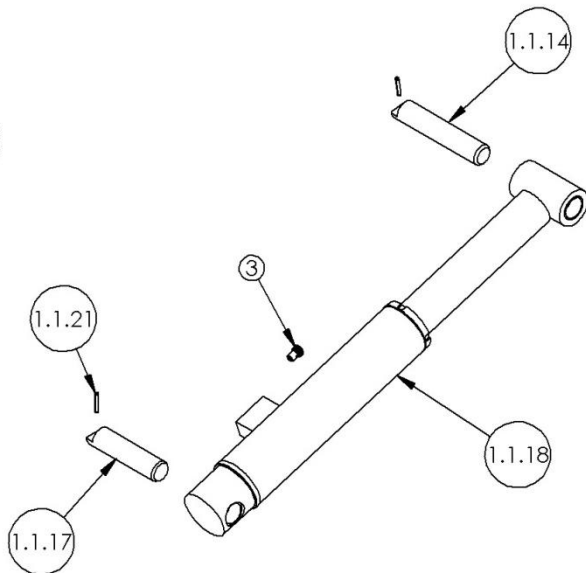

DETAIL F

LOCATION: C:\PDM Vault\Archive\27\

FILE: 27-001-101-002.SLDDWG

4/2/2020

EHLTX Base Assembly Bill of Materials, EHLTX-####-1-39 and EHLTX-####-2-39 models

ITEM	PART NUMBER	DESCRIPTION	QTY
1.1.6	27-527-007	ASSEMBLY, ROLLER (DECK/FRAME)	4
1.1.7	27-527-008	ASSEMBLY, ROLLER	2
1.1.8	27-527-009	ASSEMBLY, ROLLER	2
1.1.10	27-612-007	WELDMENT, PIN, FRAME HINGE	2
1.1.11	27-612-002	WELDMENT, PIN ASSY, FRAME HINGE	2
1.1.12	27-612-004	WELDMENT, PIN ASSY, FRAME HINGE	2
1.1.13	01-115-001	WASHER, THRUST BEARING, 1 1/8 ID	6
1.1.14	01-112-001	PIN, CLEVIS, CYLINDER, W/STOP BOSS	2
1.1.16	05-112-003	PIN, ROLLER	2
1.1.17	26-112-002	PIN, AXLE	2
1.1.18	99-021-914	CYLINDER, HYDRAULIC, 2" x 10" RAM STYLE W/ CROSS TUBE	2
1.1.19	33424	MACHINE BUSHING, PLAIN FINISH, Ø3/4" X 18 GA	8
1.1.20	33454	NARROW MACHINERY BUSHING, PLAIN FINISH, 1 3/4" X 18 GA	26
1.1.21	64134	SPRING PIN	6
1.1.22	68021	EXTERNAL RETAINING RING, PHOSPHATE FINISH, 1 1/8"	10
1.1.23	428277	3/4sz EXTERNAL HEAVY DUTY SPIRAL RING	4
1.1.24	27-612-006	WELDMENT, PIN, DECK HINGE	2
2	27-537-003	WELDMENT, MAIN. PROP	2
3	01-531-002	VELOCITY FUSE, 2 GPM	2

MASTER EXPLODED VIEW
EHLTX-####-3-39 AND EHLTX-####-3.5-39

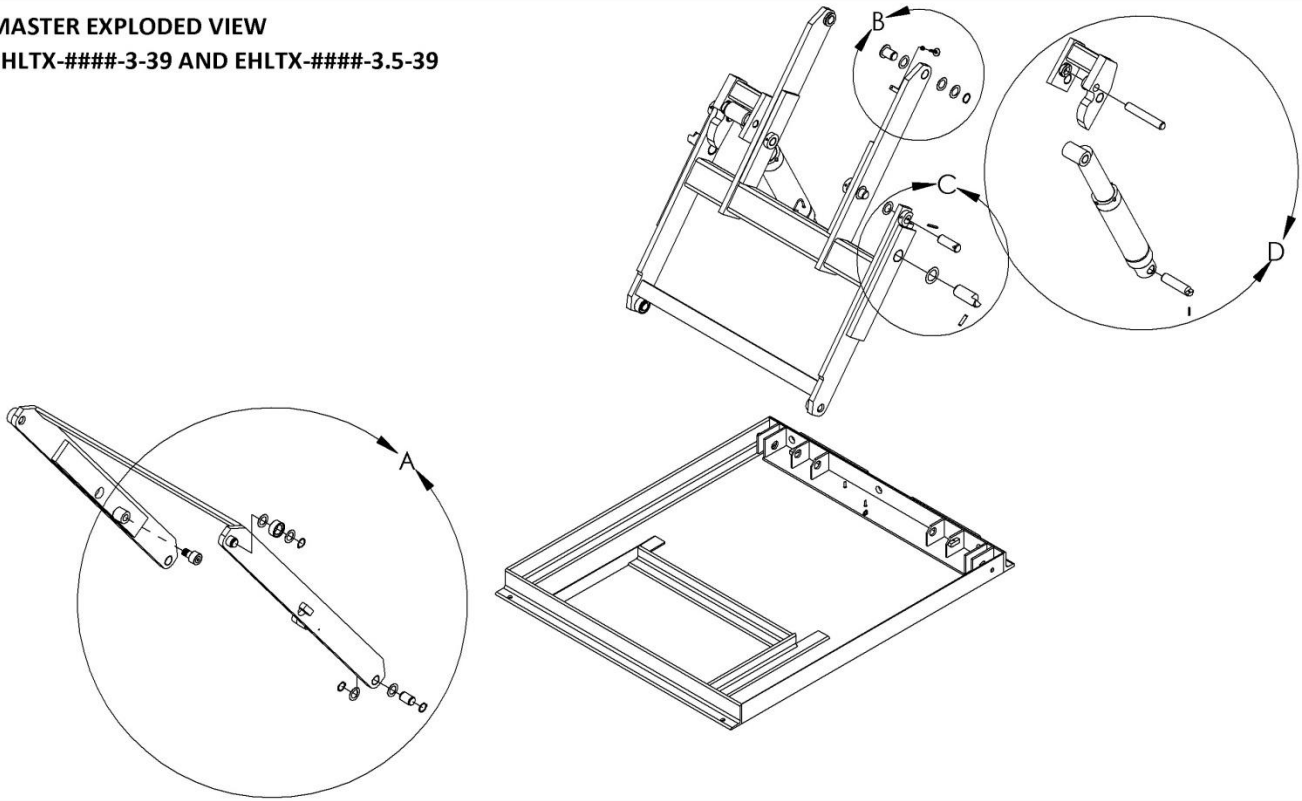

LOCATION: C:\PDM Vault\Archive\27\

FILE: 27-002-150.SLDDRW

5/14/2020

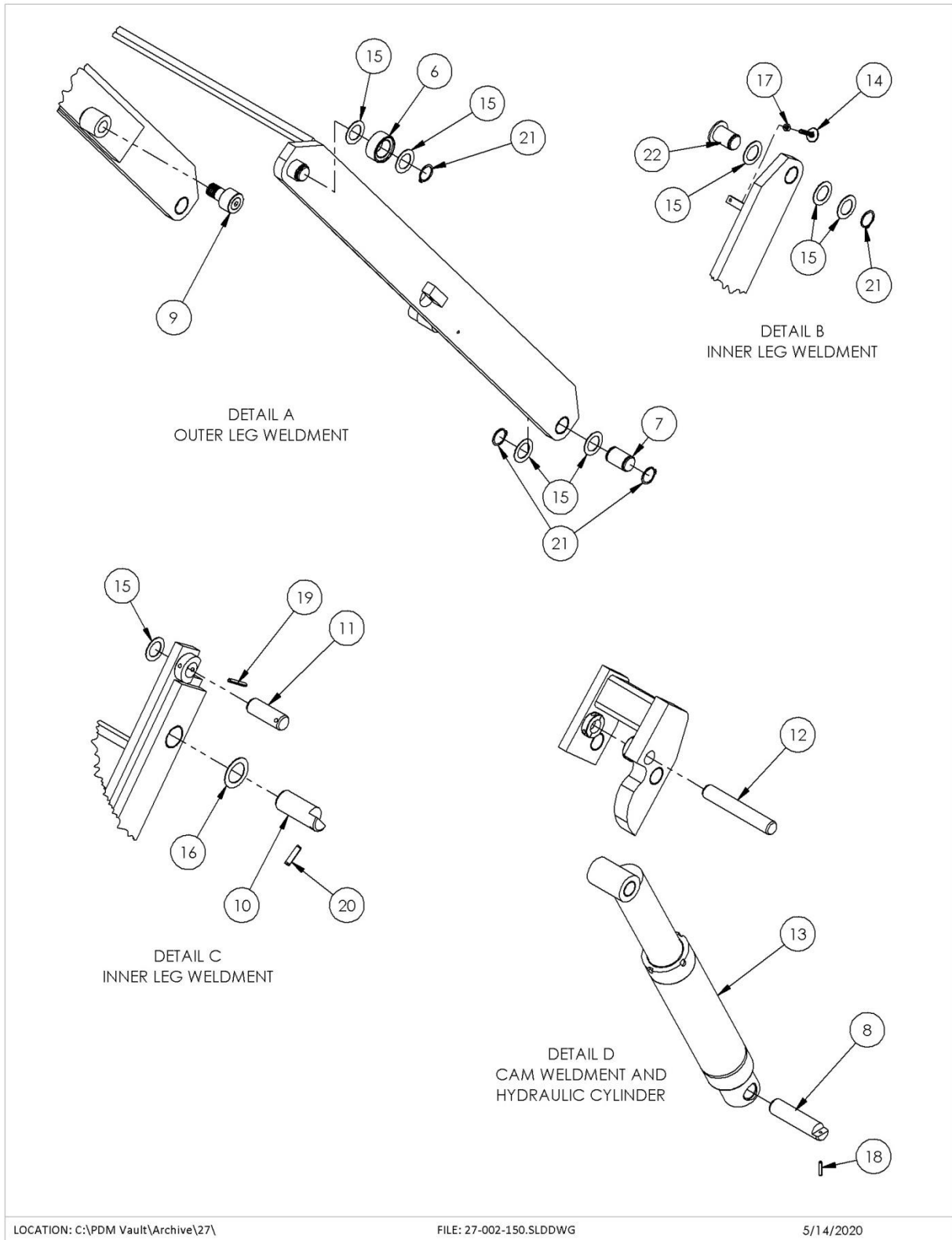

EHLTX Base Assembly Bill of Materials, EHLTX-####-3-39 and EHLTX-####-3.5-39 models

ITEM	PART NUMBER	DESCRIPTION	QTY
6	27-527-006	ASSEMBLY, ROLLER	4
7	01-112-004	PIN, CLEVIS	2
8	26-112-002	PIN, AXLE	2
9	27-110-007	BEARING CAM ROLLER, 1 1/2 CROWNED	2
10	27-112-005	PIN, SCISSOR PIVOT	2
11	27-112-006	PIN, CAM PIVOT	4
12	27-112-007	PIN, CYL. CAM	2
13	99-021-911-001	CYLINDER, HYDRAULIC, Ø2 1/2" X 8 1/2", RAM STYLE, MACHINED END	2
14	22804	FLAT COUNTERSUNK HEAD ELEVATOR BOLT, PLAIN FINISH, 1/4-20X1.5	1
15	33454	NARROW MACHINERY BUSHING, PLAIN FINISH, 1 3/4" X 18 GA	22
16	33474	SPACER, SHIM, 1 1/2" ID X 2 1/4 OD X 18 GA	2
17	36102	HEX NUT, GRADE A, ZINC PLATED, 1/4-20	1
18	64134	SPRING PIN	2
19	64255	Ø0.25 x 2 LG SPRING PIN	4
20	64311	PIN, SPRING Ø 3/8 X 1 1/2" LG	2
21	68021	EXTERNAL RETAINING RING, PHOSPHATE FINISH, 1-1/8"	10
22	27-612-006	WELDMENT, PIN, DECK HINGE	2

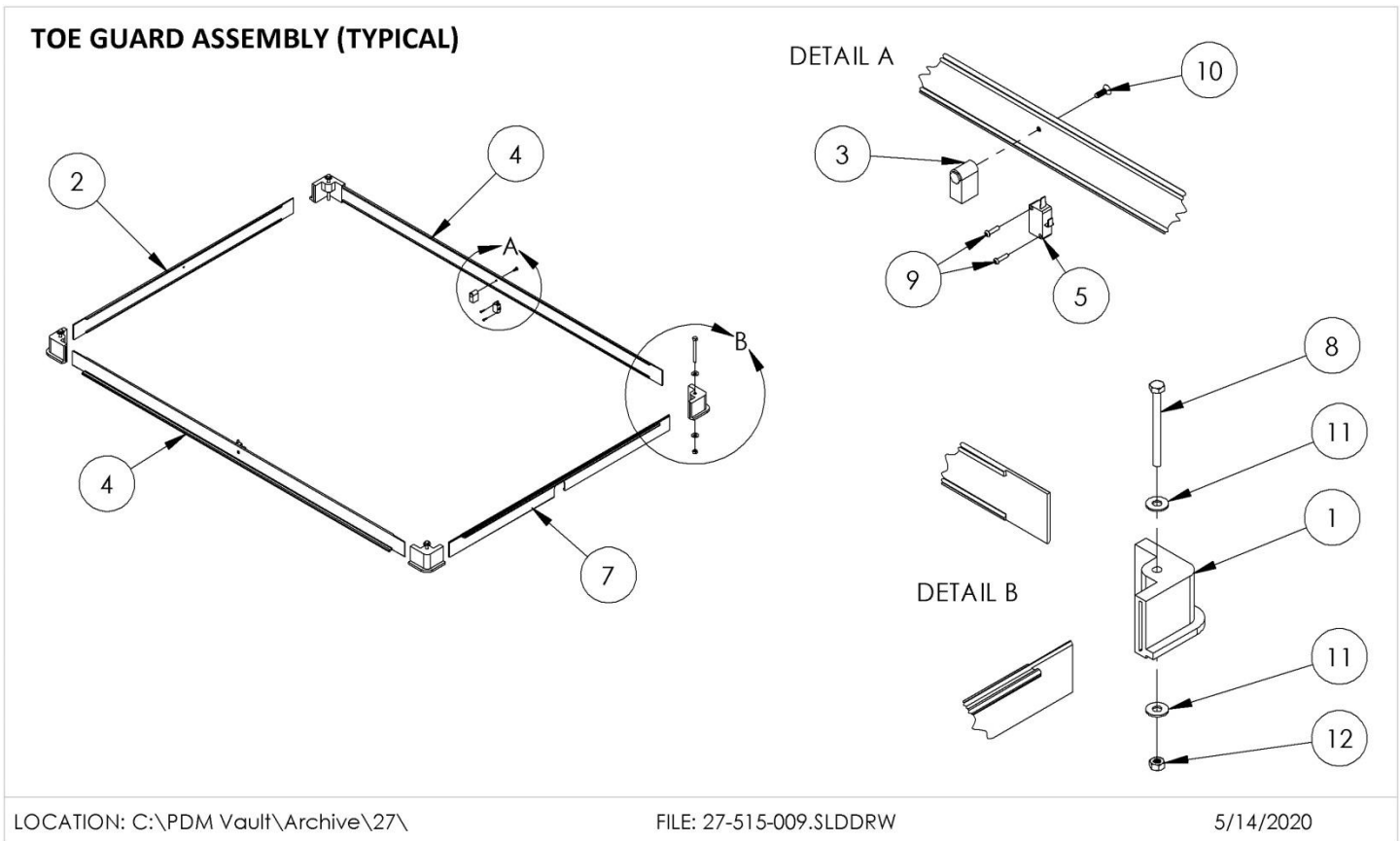

EHLTX Perimeter Toe Guard Assembly Bill of Materials

ITEM	PART NUMBER	DESCRIPTION	QTY.
1	01-015-009	TOE GUARD SUPPORT, CAST RUBBER HOUSING	4
2, 4, 7		TOE GUARD CONTACT FACTORY FOR YOUR SPECIFIC MODEL	4
3	01-015-017	TOE GUARD, LIMIT SWITCH ACTUATOR	2
5*	01-022-022	SWITCH, LIMIT (N. C. MICRO)	2
6	01-145-010	SPECIALTY HARDWARE, TOEGUARD	2
8	11015	HEX BOLT, GRADE A, ZINC PLATED, 1/4"-20 X 3"	4
9*	24008	4-40 X 1/2 BHCS	4
10	24189	8-32 FHSCS	2
11	33004	FLAT WASHER, USS, ZINC PLATED, Ø1/4"	8
12	37018	NYLON LOCK NUT, GRADE 2, ZINC FINISH, 1/4"-20	4

* Item attaches separately to platform.

ELECTRICAL AND HYDRAULIC SYSTEM DIAGRAMS

⚠ WARNING Care should be taken to identify all potential hazards and comply with applicable safety procedures before beginning work. Ensure that all system pressure and electrical power have been removed before attempting to work on the electrical or hydraulic systems. Follow all applicable lockout/tagout procedures.

⚠ WARNING The load must be removed, and the platform either positively and adequately supported or fully lowered, before any work is performed on the lift table.

Only qualified individuals trained to understand mechanical devices and their associated electrical and hydraulic circuits, as well as the hazards associated with them, should attempt troubleshooting and repair of this equipment.

EHLTX Power Unit Assembly.

Representative drawing. Contact the factory for replacement parts for your specific model. ALWAYS have the product serial number or model number on hand when calling the factory.

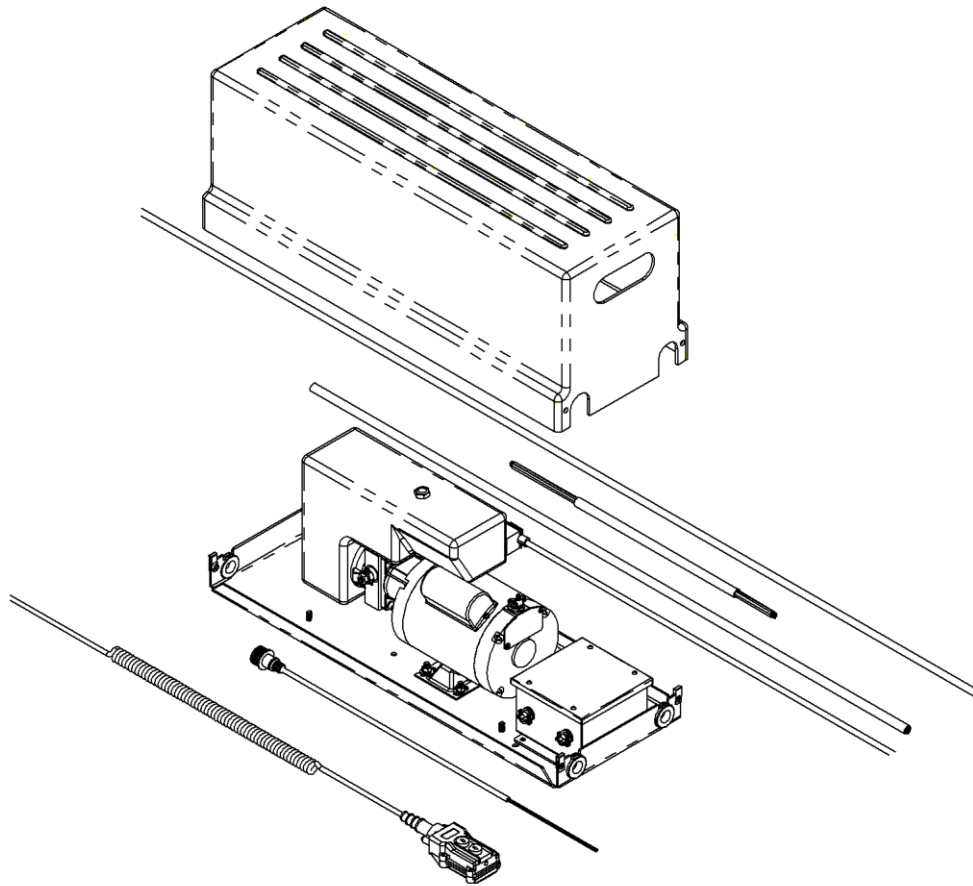
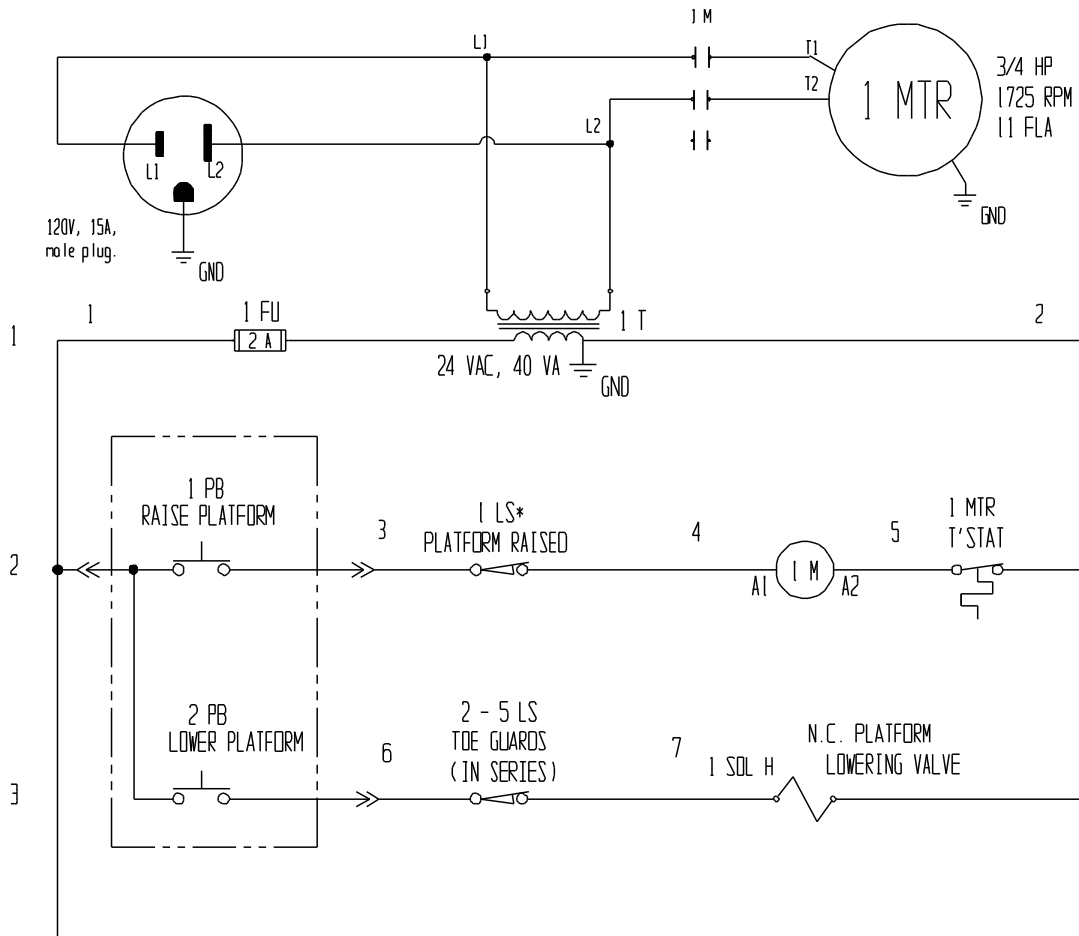

TABLE CAPACITY	MOTOR VOLTAGE	POWER UNIT PART NUMBER
1000 lb, 2000 lb (EHLTX-####-1-39, EHLTX-####-2-39)	115 VAC 1 Ø	99-660-159-001
	208-230 VAC 1 Ø	99-660-159-002
	230/460 VAC 3Ø	99-660-163-004
3000 lb, 3500 lb (EHLTX-####-3-39, EHLTX-####-3.5-39)	115 VAC 1 Ø	99-660-160-001
	208-230 VAC 1 Ø	99-660-160-002
	230/460 VAC 3Ø	99-660-164-004

115 VAC, Single-Phase Electric Circuit Diagram (27124002 Rev. B)

Note: Overcurrent & short circuit protection and disconnect must be provided by end user.



* NOTE: Pressure switch replaces limit switch in narrow-body EHLTX-####-3-39 and EHLTX-####-3.5-39 models. Pressure switch will be mounted on manifold.

208-230 VAC, Single-Phase Electric Circuit Diagram (27124003 Rev. B)

Note: Overcurrent & short circuit protection and disconnect must be provided by end user.

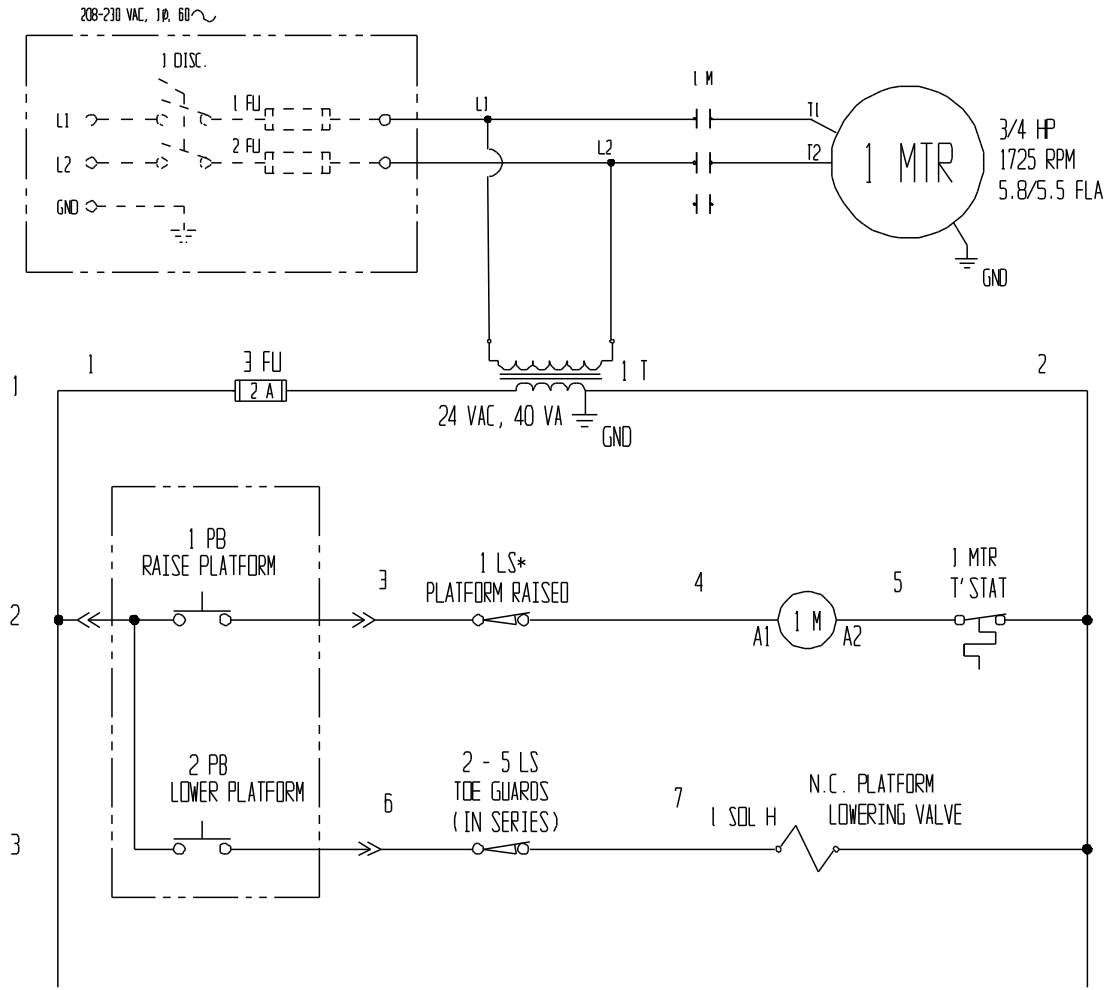

* NOTE: Pressure switch replaces limit switch in narrow-body EHLTX-####-3-39 and EHLTX-####-3.5-39 models. Pressure switch will be mounted on manifold.

Three-Phase Electric Circuit Diagram (27124004 Rev. B)

Note: Overcurrent & short circuit protection and disconnect must be provided by end user.

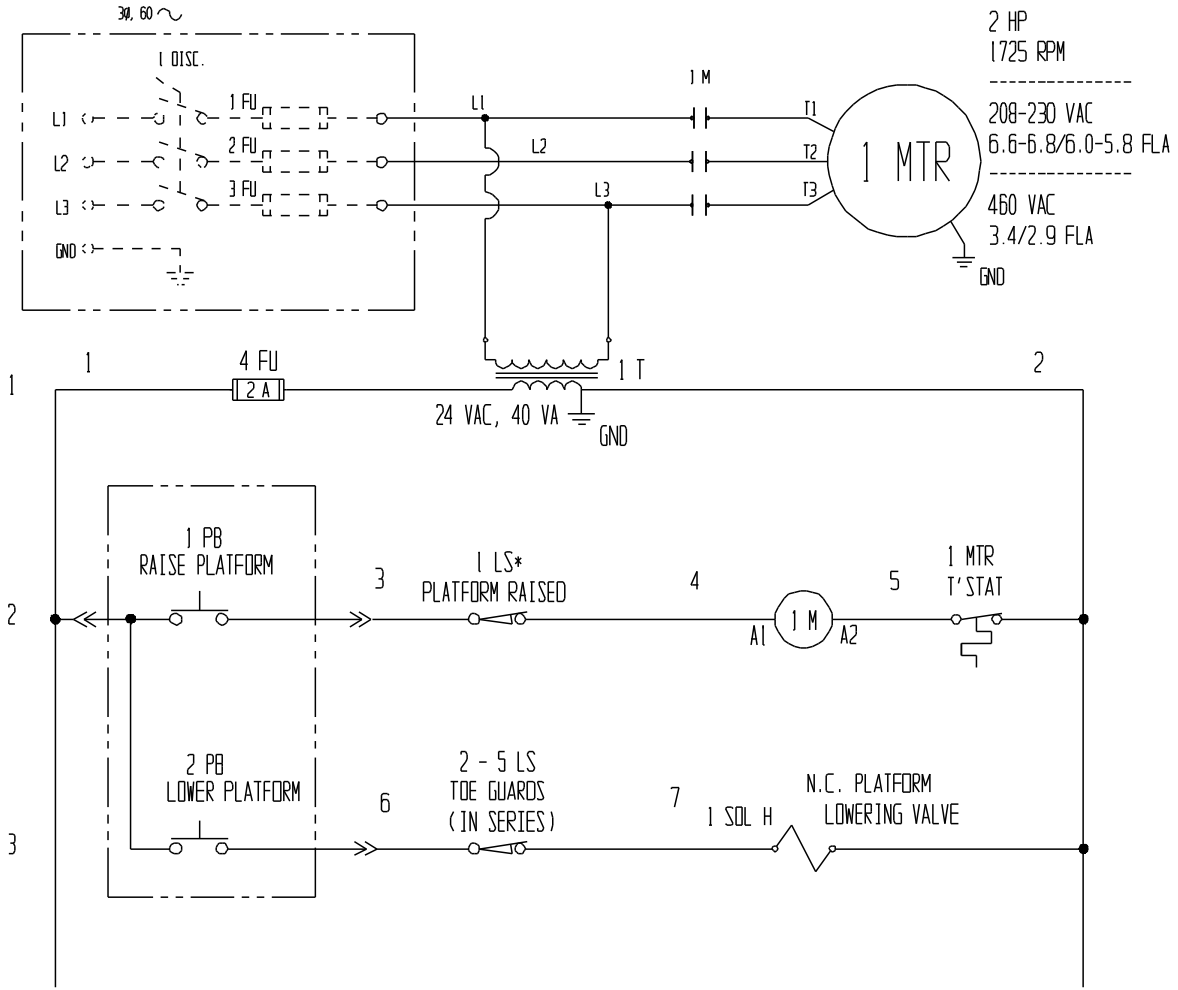

* NOTE: Pressure switch replaces limit switch in narrow-body EHLTX-####-3-39 and EHLTX-####-3.5-39 models. Pressure switch will be mounted on manifold.

Motor Lead Connections (99124021).

Applicable to all all .5 HP, .75 HP, and 3 HP single-phase motors, and for all 2 HP, 5.5 HP, and 6.5 HP three-phase motors.

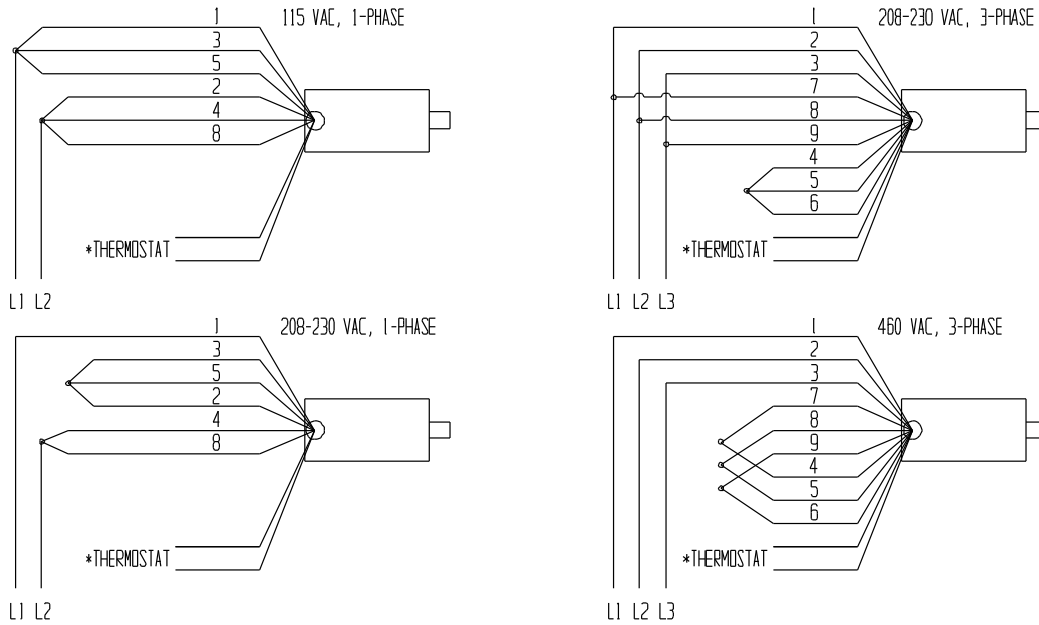

* The two thermostat leads go to (1) the grounded side of the transformer secondary, and; (2) the motor relay coil. Polarity across the thermostat leads may be reversed.

⚠ WARNING When changing the motor voltage configuration, you must also change the configuration of the control transformer to match the motor voltage.

Control Voltage Transformer (01129001 Rev. G).

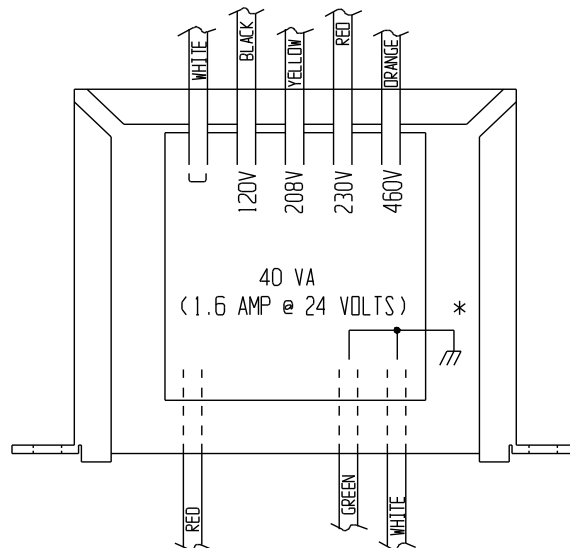

Motor/Pump Unit.

Representative drawing. Contact the factory for replacement parts for your specific model. ALWAYS have the product serial number or model number on hand when calling the factory.

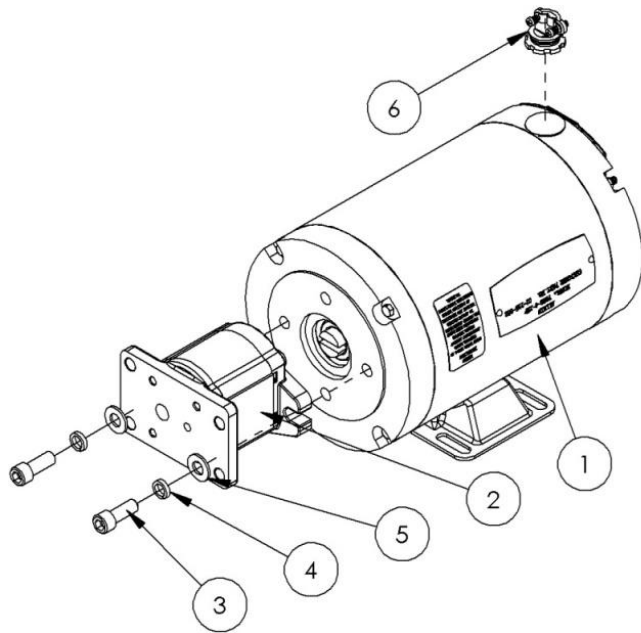

ITEM	PART NO.	DESCRIPTION	QTY
1	115 V, 208-230V 99-135-003	MOTOR, 3/4 HP, 1PH, 1725 RPM, 56F, 115/208- 230, 60HZ	1
	230/460V 3Ø 99-135-005	MOTOR, 2 HP, 3PH, 1725 RPM, 56F, 208- 230/460V, 50/60HZ	
2	115 V, 208-230V 01-143-906-002	PUMP, HYDRAULIC GEAR, .073 DISP, 1.3 cc/r	1
	230/460V 3Ø 01-143-908-002	PUMP, HYDRAULIC GEAR, .153 DISP, 2.7 cc/r	
3	23305	SHCS, 3/8 - 16 x 1 LG.	2
4	33688	LOCK WASHER, HIGH COLLAR, 3/8	2
5	96056	WASHER, FLAT, 3/8" NOMINAL, .406" I.D., YELLOW ZINC SAE	2
6	99-034-037	ACCESSORIES, ELECTRICAL, ROMEX .375"	1

Manifold Assembly (01-627-014 Rev. A; 01-627-015, Rev. A).

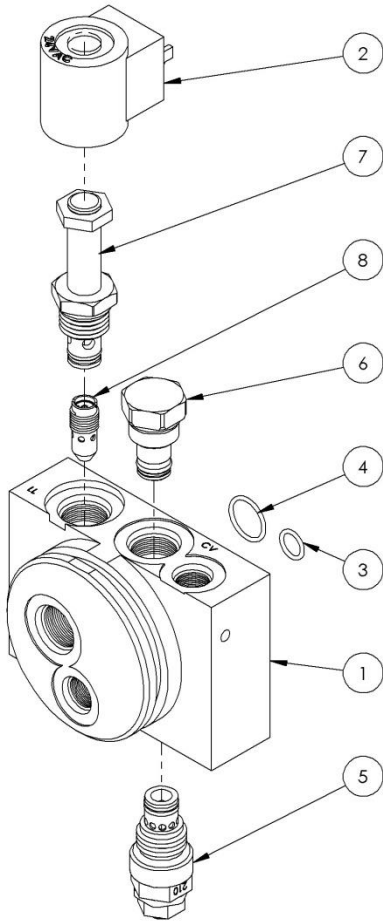

ITEM	PART NO.	DESCRIPTION	QTY
1	01-127-010	MANIFOLD, L-H-L	1
2	99-034-008	COIL WITH DIN CONNECTOR	1
3	99-144-008	O-RING, MANIFOLD, 1/2" OD	1
4	99-144-009	O-RING, MANIFOLD, 3/4" OD	1
5	99-153-006	VALVE, PRESSURE RELIEF, 210 BAR	1
6	99-153-011	CHECK VALVE, SIZE 08, NOSE-IN/SIDE-OUT	1
7	99-153-015	VALVE SOLENOID, STANDARD, w/o COIL	1
8	1000-lb, 2000-lb 99-153-039	FLOW CONTROL, PRES. COMP., 1.5 GPM.	1
	3000-lb, 3500-lb 99-153-040	FLOW CONTROL, PRES. COMP., 2.0 GPM.	

Hydraulic Schematic (01-125-008).

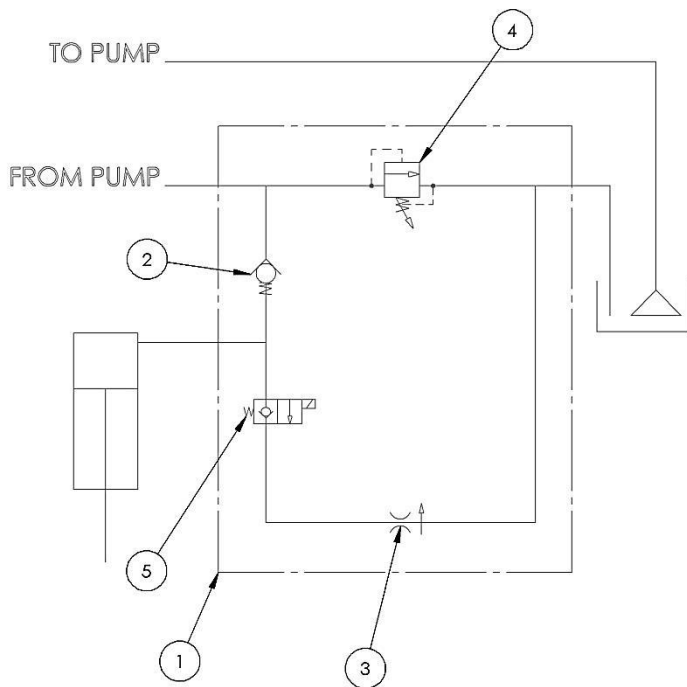

ITEM	PART NO.	DESCRIPTION	QTY
1	01-127-010	MANIFOLD, LHL	1
2	99-153-011	CHECK VALVE, SIZE 08, NOSE-IN/SIDE-OUT	1
3	1.5 GPM 99-153-039	FLOW CONTROL, PRES. COMP.	1
	2.0 GPM 99-153-040		
4	99-153-006	VALVE, PRESSURE RELIEF, 210 BAR	1
5	99-153-015	VALVE SOLENOID, STANDARD, w/o COIL	1

INSTALLATION INSTRUCTIONS

Review this entire section before installing the scissor lift table. Consult the factory in the event of questions or problems at the time of installation.

Modifications or additions to the lift table, without prior authorization by the manufacturer, may void the warranty. See ANSI standard MH29.1-2003, *Safety Requirements for Industrial Scissor Lifts*, Section 12.6. Attaching ancillary equipment to the platform will lower its load capacity.

The installation shall comply with all applicable regulations for its location and use.

The end user is responsible for verifying that this lift table and its installation are suitable for its environment and application.

This lift table shall be installed only by qualified and trained personnel with access to appropriate equipment. Electrical connections shall be performed by a qualified electrician.

Before You Begin.

The Electric Hydraulic Scissors Lift Table must be anchored to a smooth, level, and adequately strong concrete surface. See the INSTALLATION DIMENSIONS diagrams and table to plan your installation.

Before placing the lift table in a pit, determine the routing for the electric and hydraulic lines connecting the table with its power unit. A cable and hose bundle, 7'-6" in length, connects the EHLTX table to the external power unit. Contact the factory if different connections are needed.

Tools And Supplies.

The following tools and supplies may be needed to install your Electric Hydraulic Scissor Lift Table. These items are not supplied with the product.

- A fork truck or hoist capable of unloading the lift table and setting it in place.
- A smooth, level concrete surface on which to mount the lift table.
- Four concrete anchors. The customer is responsible for selecting anchors appropriate for the EHLTX model and concrete floor conditions. **DO NOT** operate an unsecured lift table.
- A power supply and electrical disconnect matching the power unit's voltage and current requirements. Refer to the lift table's data plate, labels on the control enclosure, and the electrical diagrams in this manual for more information. The end-user is responsible for supplying the required ground-fault and short-circuit protection on the supply. Motor overload protection is provided by a thermostat built into the motor.

Installation Dimensions.

The bottom views of representative EHLTX lift tables are shown. When installing in a floor pit, provide a clearance of at least 1/4" but no more than 7/8" clearance on all sides. Consider the routing of electric and hydraulic lines when designing your pit installation.

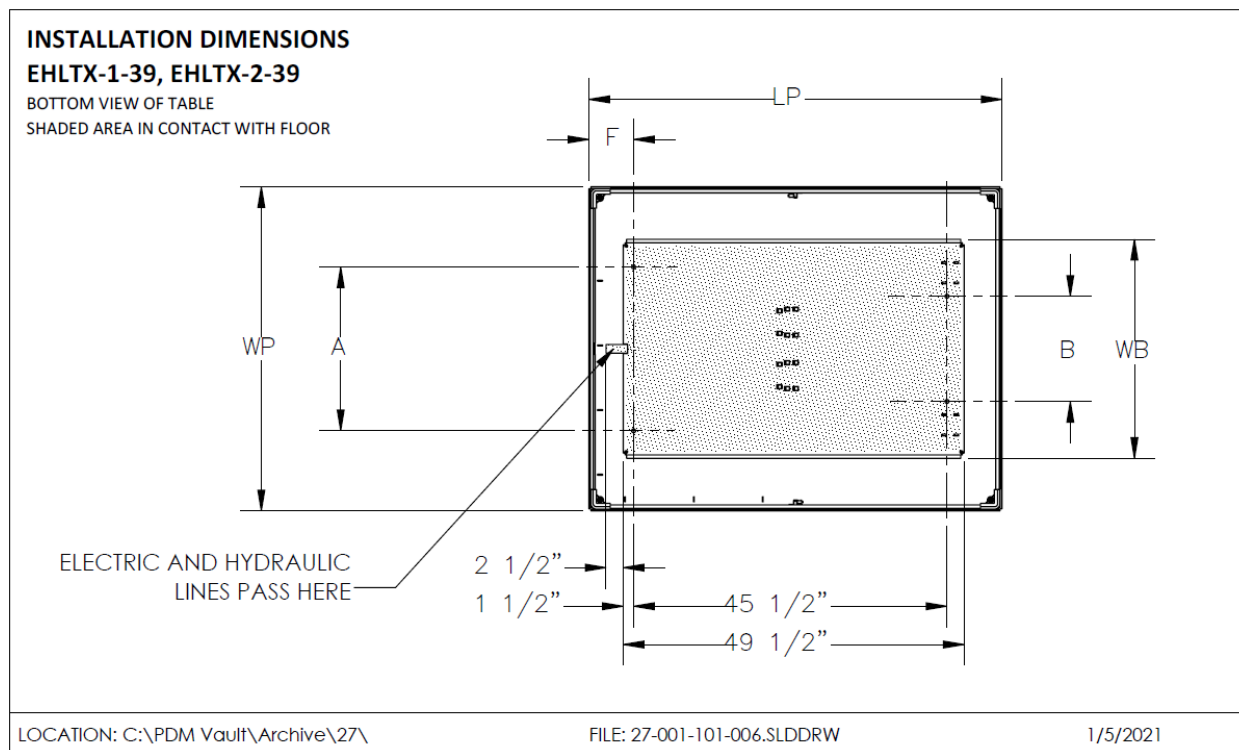

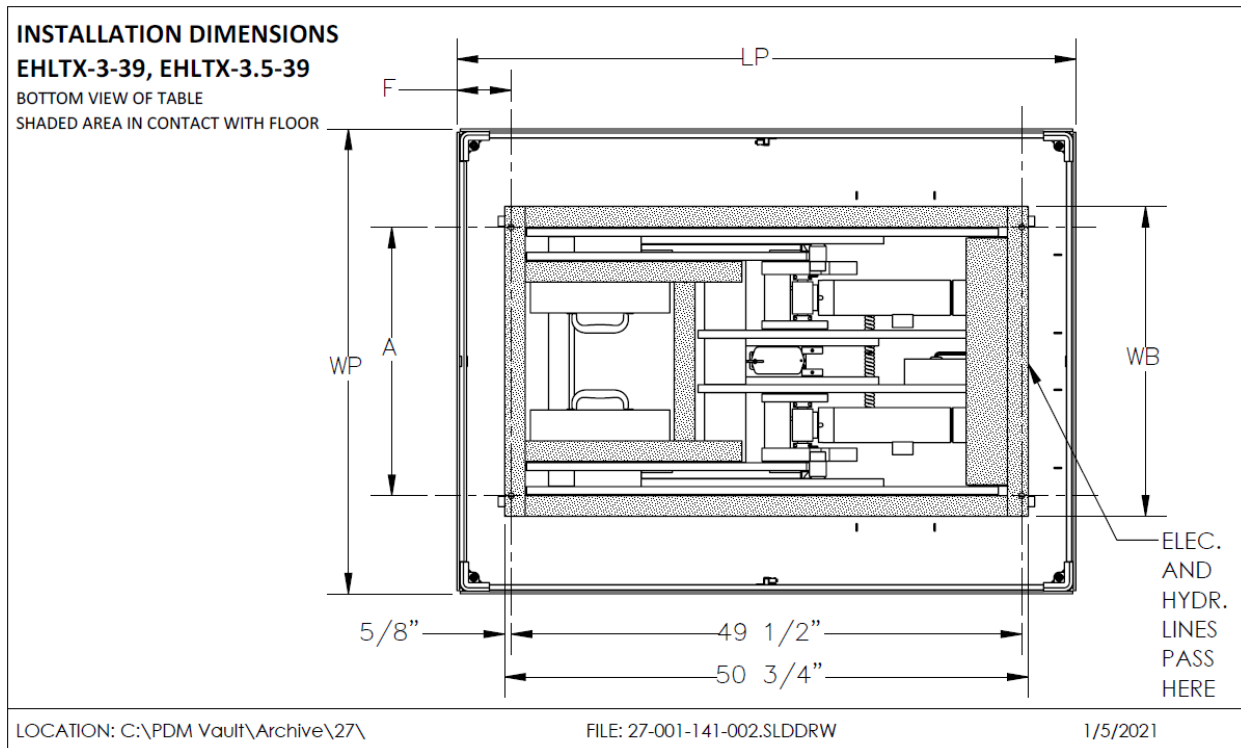

MODELS	BASE DIMENSIONS			PLATFORM DIMENSIONS		
	WB	A	B	WP	LP	F
EHLTX-3653-1-39 EHLTX-3653-2-39	31 3/4"	23 3/4"	15 1/4"	36"	53"	3"
EHLTX-3656-1-39 EHLTX-3656-2-39	31 3/4"	23 3/4"	15 1/4"	36"	56"	4 1/2"
EHLTX-3660-1-39 EHLTX-3660-2-39	31 3/4"	23 3/4"	15 1/4"	36"	60"	6 1/2"
EHLTX-4753-1-39 EHLTX-4753-2-39	31 3/4"	23 3/4"	15 1/4"	47"	53"	3"
EHLTX-4756-1-39 EHLTX-4756-2-39	31 3/4"	23 3/4"	15 1/4"	47"	56"	4 1/2"
EHLTX-4760-1-39 EHLTX-4760-2-39	31 3/4"	23 3/4"	15 1/4"	47"	60"	6 1/2"
EHLTX-4853-1-39 EHLTX-4853-2-39	43 1/4"	35 1/4"	26 3/4"	48"	53"	3"
EHLTX-4856-1-39 EHLTX-4856-2-39	43 1/4"	35 1/4"	26 3/4"	48"	56"	4 1/2"
EHLTX-4860-1-39 EHLTX-4860-2-39	43 1/4"	35 1/4"	26 3/4"	48"	60"	6 1/2"
EHLTX-5153-1-39 EHLTX-5153-2-39	43 1/4"	35 1/4"	26 3/4"	51"	53"	3"
EHLTX-5454-1-39 EHLTX-5454-2-39	43 1/4"	35 1/4"	26 3/4"	54"	54"	3 1/2"
EHLTX-5656-1-39 EHLTX-5656-2-39	43 1/4"	35 1/4"	26 3/4"	56"	56"	4 1/2"

EHLTX-6053-1-39 EHLTX-6053-2-39	43 1/4"	35 1/4"	26 3/4"	60"	53"	3"
EHLTX-6060-1-39 EHLTX-6060-2-39	43 1/4"	35 1/4"	26 3/4"	60"	60"	6 1/2"
EHLTX-3653-3-39 EHLTX-3653-3.5-39	30"	26"	N/A	36"	53"	1 3/4"
EHLTX-4560-3-39 EHLTX-4560-3.5-39	30"	26"	N/A	45"	60"	5 1/4"
EHLTX-4653-3-39 EHLTX-4653-3.5-39	42"	38"	N/A	46"	53"	1 3/4"
EHLTX-4853-3-39 EHLTX-4853-3.5-39	42"	38"	N/A	48"	53"	1 3/4"
EHLTX-6060-3-39 EHLTX-6060-3.5-39	42"	38"	N/A	60"	60"	5 1/4"

NOTE: Power connections on EHLTX-1-39 and EHLTX-2-39 models are on free end of unit (left side of installation drawing). Power connections on EHLTX-3-39 and EHLTX-3.5-39 models are on hinged end of unit (right side of installation drawing).

Installation.

1. Plan for your lift table installation prior to installation. Consider placement of the power unit and routing for electric and hydraulic lines.
2. The platform must be lowered and fully supported under its frame when moved. Support the lift table with straps or forks that span the entire width or length of the base frame. Remove the 4x4 wood dunnage from the base. Use care to avoid damaging the electrical and hydraulic components in the lift table.
3. Move the lift table into position.
4. Plug in or temporarily connect the power unit. Raise the platform to its full height. Place one maintenance prop in each scissor leg roller track (maintenance props are stored in the base weldment). Lower the platform until the props slide up against the end frame on the base, supporting the platform.



5. Anchor the frame to the floor through the four mounting holes in the base. Use shims and/or grout to support the entire length of each base side frame. The entire base frame rail must be supported with no gaps in its foundation for the lift table to function properly. For EHLTX-3-39 and EHLTX-3.5-39 models, the roller rail frame must also be completely supported by shims and/or grout.
6. Have a qualified electrician make the permanent connection from customer's electric supply to the power unit.

7. Operate the lift table through several full raise and lower cycles.
 - a. Verify that actuating the upper travel limit switch (mounted under the platform) prevents further upward travel of the platform. Narrow-base EHLTX-####-3-39 and EHLTX-####-3.5-39 models (platform width 47" or less) use a hydraulic pressure switch in place of the limit switch.
 - b. Verify that actuating either of the perimeter toe guard switches (centered on each side of the platform) prevents downward travel of the platform.
 - c. DO NOT place a lift table in service if either of these devices isn't functioning properly.



TOE GUARD LIMIT SWITCH (UNDER PLATFORM)

8. Check the hydraulic oil level. It should be filled to within 1" to 1-½" of the reservoir's fill hole. If oil is needed, use an anti-wear hydraulic oil with a viscosity grade of 150 SUS at 100°F (ISO 32 at 40°C) or a non-synthetic automatic transmission fluid.
9. Clean up any debris or spilled oil. Verify that all of the information, safety, and warning labels are in good condition.

ACCESSORIES

Vestil offers table skirts and approach ramps as accessories for your EHLTX lift table.

Accordion skirt (ACC).

Accordion skirts serve both functional and safety purposes. Skirts keep debris from damaging the operating mechanism, hydraulic components, and electrical parts. Safety is provided by keeping an operator's legs, fingers, and toes out from under the table. Skirting is 23 ounce vinyl with reinforcing metal rods every other convolution. Standard electric toe guards are not included when a lift table is fitted with accordion skirt option. Skirting is not meant to be used on units being installed in a pit or with a ramp. Vinyl skirts are compliant with the NFPA 701 Life Safety Code and OSHA pinch point specifications.

Skirting may be installed as a factory option or retrofitted to existing units in the field. Heavy-duty Velcro attaches the skirt to the EHLTX lift table. Accordion skirts are special-order and not returnable.

Approach ramp and approach ramp spacer (ARX and ARX-RS).

Approach ramps (ARX models) allow the customer to use hand or pallet trucks to load and unload a low-profile lift table. Approach ramp spacers (ARX-RS models) provide a level platform between the ramp and the table. The load capacity for all ARX and ARX-RS models is 4000 lb.

Use four ½” concrete anchors (not included with unit) to secure the approach ramp or approach ramp spacer to the floor before use. Approach ramps cannot be used on lift tables having an accordion skirt.

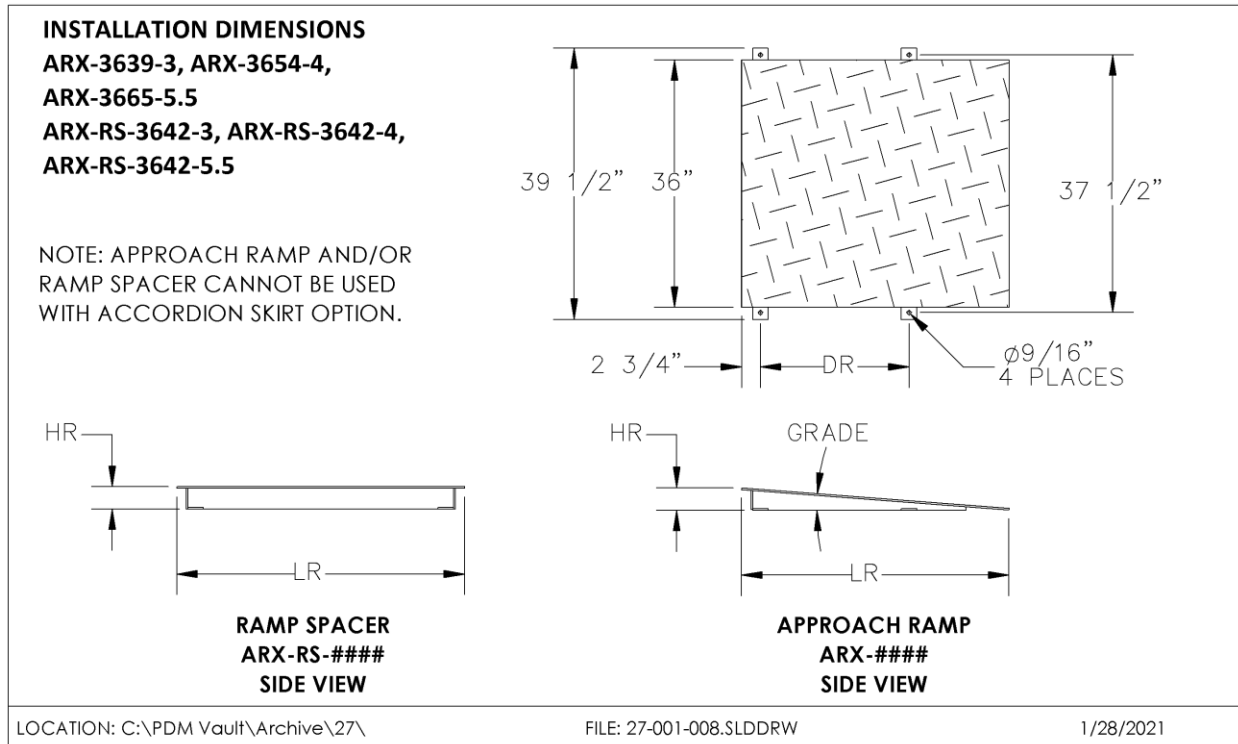

MODEL	LR	HR	DR	GRADE	WEIGHT
ARX-3639-3	39"	3 1/4"	21 11/16"	7.5%	126 lb
ARX-3654-4	54"	4 1/2"	37 7/8"	7.5%	189 lb
ARX-3665-5.5	64 13/16"	5 1/2"	37 7/8"	8%	240 lb
ARX-RS-3642-3	42"	3 1/4"	36 1/2"	N/A	171 lb
ARX-RS-3642-5	42"	4 1/2"	36 1/2"	N/A	197 lb
ARX-RS-3642-5.5	42"	5 1/2"	36 1/2"	N/A	218 lb

RECORD OF SATISFACTORY CONDITION

After assembling and installing the scissor lift table, and before using it for the first time, make a record describing its appearance. Thoroughly photograph the lift table from multiple angles, including all welds and anchor points, and all labeling applied to it. Describe where each label is located. Collect all photographs and writings into a file. Mark the file appropriately to identify it. This record documents satisfactory condition. Compare the results of future inspections to this record to determine if the lift table is in satisfactory condition. Do not use the lift table unless it is in satisfactory condition. Purely cosmetic changes, like damaged paint or powder coat, do not constitute changes from satisfactory condition. However, touchup paint should be applied to all affected areas as soon as damage occurs.

OPERATION INSTRUCTIONS

Consult ANSI standard MH29.1, Section 12 for the owner's/user's responsibilities regarding the operation, care, and maintenance of this machine.

The user shall ensure that operators understand that safe operation is the operator's responsibility. The user shall also ensure that operators are knowledgeable of, and observe, the safety rules and practices in this section.

This low-profile scissor lift table is suitable for use indoors in most non-classified industrial locations and many commercial locations. It is intended to lift stable, evenly-distributed, nonhazardous materials loads having a size or footprint approximately the same size as the platform.

The drawing identifies the major components of your scissors lift table.

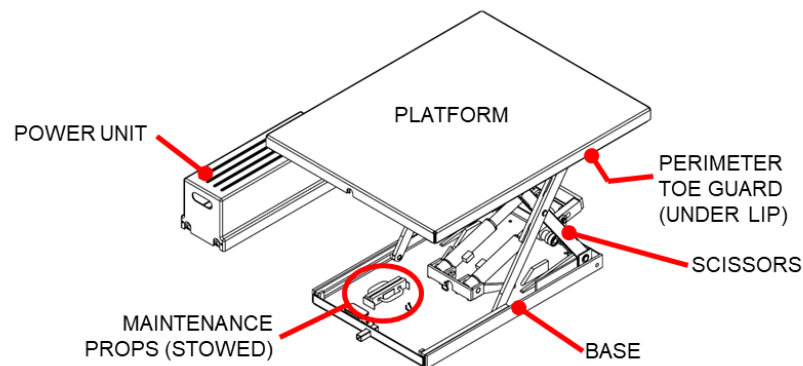

Loading the platform.

The load rating, in pounds, is shown on the machine data plate located on the hinged end of the platform. This indicates the net capacity of the scissor lift table for a static load, centered and evenly distributed on the platform. For off-center loads, the lift table's maximum capacity is 50% of the rated capacity for end loading (either end), and 25% for side loading (either side) (see diagram).

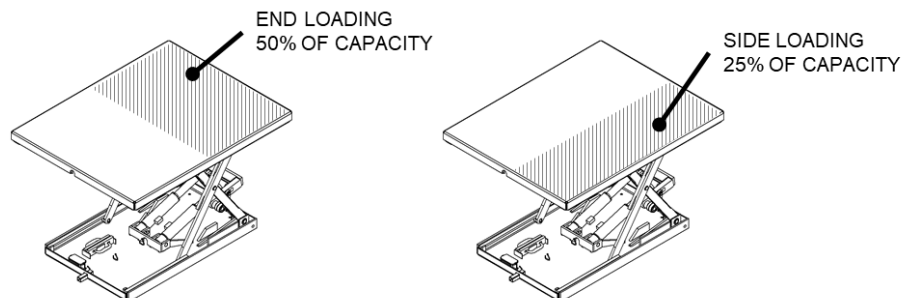

WARNING

DO NOT exceed the lift table's load ratings. Injury to personnel or permanent damage to the lift table can result from exceeding the listed capacity. Note: Take into account the weight of any equipment added to the platform by third parties when determining the maximum working load to be placed on the platform.

WARNING

The platform rollers are not captured. *DO NOT* overhang any load over the side of the platform. A cantilevered or overhanging load at the hinged end can cause the platform to tilt and dump the load. For applications involving side or end edge loading, consult the factory.

WARNING

This lift table is not approved for lifting personnel.

Operation.

At the beginning of every shift, inspect the perimeter toe guard for correct operation. First raise the platform. Push and hold a section of the perimeter toe guard up against the platform. The platform should not move when the "LOWER" button is pressed. Perform this check on all four sides of the platform.

Check the condition of the guards, controls, scissor mechanism, hydraulic lines, and limit switches. If any item is in need of repair or otherwise contributes to an unsafe condition, remove the lift table from service until it has been restored to a safe operating condition.

The standard EHLTX scissor lift table is furnished with an externally-mounted electric-hydraulic power unit and a handheld pushbutton control.

- Press the "RAISE" pushbutton to energize the power unit and raise the platform. The platform will rise only while the pushbutton is pressed. When the pushbutton is released, the platform will stop and hold its position. At the platform's maximum height, a limit switch prevents the platform from further raising.
- Press the "LOWER" pushbutton to open the hydraulic valve and lower the platform. The platform descends by gravity, and the pump motor will not run. Release the pushbutton to stop the motion of the platform. If the perimeter toe guard encounters an object, the valve will close and prevent further descent of the platform.
- The EHLTX lift table is provided with hydraulic overload protection that will prevent it from raising a load in excess of its rated capacity. The lowering speed is preset at the factory, and will not exceed a speed of 30 fpm. In the event of a hydraulic line failure, a velocity fuse in the hydraulic cylinder will prevent the platform from lowering.

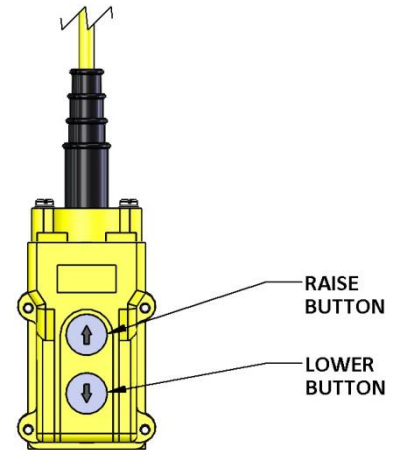

CAUTION

Always watch the area around the platform and any load on the platform when it is in operation.

CAUTION

Never use the lift table if any damage or unusual noise is observed, if it is in need of repair, or if any other malfunction is observed. Notify your supervisor or maintenance personnel.

WARNING

Keep all personnel clear of the machine when it is in operation. Before operating the lift table, make certain no part of any person or object is under the platform.

WARNING

Guards shall be in place before operating the lift table.

WARNING

Guards cannot protect against every possible condition, and should not be considered a substitute for good judgment and care in use, loading, handling, storage, etc. of the lift table.

INSPECTION AND MAINTENANCE

Proper maintenance is essential for maximizing the service life of this product. If an inspection reveals any irregularities in the lift table's condition, repair it before returning it to service. Only use manufacturer-approved replacement parts. Contact Technical Service if you have questions that are not addressed in these instructions or if you are uncertain how to address an issue discovered during an inspection. Technical Service can be contacted by calling (260) 665-7586 and asking for the Service and Parts Department or by submitting questions online at http://www.vestilmfg.com/parts_info.htm.



Care should be taken to identify all potential hazards and comply with applicable safety procedures before beginning work.



Remove any load and install the maintenance props before beginning any inspection or service on the lift table. See below.

Only qualified individuals trained to understand mechanical devices, electrical and hydraulic circuits, and the hazards associated with them, should attempt troubleshooting and repair of this equipment.

Inspection procedures.

Prior to performing any inspection or maintenance on this lift table:

- Read and understand these maintenance procedures.
- Remove the load from the platform. Do not attempt to service a loaded lift table.
- Fully lower the platform, OR use both maintenance props to support the weight of the platform. The maintenance props are stored in the base weldment. Place one prop in each scissor leg roller track. Lower the platform until the props slide up against the end frame on the base, supporting the table.
- Disconnect power and follow established lockout/tagout policies as required.

Initial inspection.

Prior to use, any new, altered, modified, or repaired scissor lift table shall be inspected by a qualified person.

Complete both the daily and monthly inspection items before releasing the lift table for regular use.

Daily inspection.

At the beginning of every shift, a designated person shall complete these inspections. Remove the lift table from service and repair or replace any damaged parts if any of the following is found.

1. Look for:
 - a. Frayed wires.
 - b. Oil leaks.
 - c. Pinched, chafed, worn, or cracking hydraulic hoses.
 - d. Damage, deformation, or cracks in any structural member or any weld. Give special attention to the hydraulic cylinder mounting brackets.
 - e. Loose or missing fasteners.
 - f. Unusual noise or evidence of binding.
2. Test the function of the upper travel limit switch and the perimeter toe guard.

Monthly inspection.

Have a qualified person inspect for:

1. Oil level. The oil should be 1" to 1-½" below the reservoir fill hole with the platform in the fully lowered position. See the Annual Inspection section for the hydraulic oil specification.
2. Worn or damaged hydraulic hoses or electrical wires.
3. Wear in the pivot points on the legs.
4. Looseness or wear in the rollers.
5. Integrity of the retaining hardware on all rollers and all pivot point pins.
6. Integrity of the frame anchor bolts, and for cracks in the concrete around them.
7. Proper functioning of any hand- or foot-operated mechanisms.
8. Unusual noises or movement during operation.
9. Condition of all information, safety, and warning labels. These should be clean and clearly legible.

10. Dirt and debris. Clean, sweep, or wipe down as needed.

Annual inspection.

Check the condition of the oil. Change the oil if it darkens, becomes gritty, or turns a milky color (indicating the presence of water). Replace with an anti-wear hydraulic oil with a viscosity grade of 150 SUS at 100°F (ISO 32 cSt @ 40°C), such as AW 32, HO 150 or Dexron non-synthetic transmission fluid. You may use a synthetic transmission fluid if you flush the system with the synthetic fluid before filling the reservoir. 150 SUS at 100°F (ISO 32 cSt @ 40°C) or Dexron transmission fluid.

Solenoid valve maintenance.

In the event that the platform creeps down slowly after releasing the "DOWN" control, it will be necessary to remove the lowering cartridge valve for inspection and cleaning.

1. Remove any load from the platform.
2. Raise the platform. Lower the maintenance props into the side frame. Lower the platform until it rests on the props.
3. The manifold assembly is part of the power unit, attached to the end of the motor and pump.
4. Remove the nut holding the solenoid coil (item 2), right) on the solenoid valve stem. Remove the coil (2), then unscrew the valve (7) from the manifold.
5. Inspect the valve for contaminants. Inspect the O-rings and back-up washers for cuts, tears, or other damage.
6. With the valve immersed in mineral spirits or kerosene, insert a thin tool such as a small screwdriver or a small hex wrench in the hole at the bottom of the valve (illustration, next page). Push the spool in and out several times. A properly functioning spool should move freely, with about 1/16" of travel. Use mineral spirits to flush the valve.
7. If the spool continues to stick, the stem could be bent. The valve will need to be replaced.
8. Blow the valve off with a compressed-air gun while again pushing the spool in and out.
9. Inspect the bottom of the manifold's valve cavity for contaminants.
10. Make sure both O-rings and outer seal (flat) are seated on the valve body. Make sure the screen filter is in place and seated at the bottom of the threads on the valve body (illustration).
11. Reinstall the solenoid valve, tightening to 20 ft-lb of torque. Reattach the solenoid coil and the retaining nut.

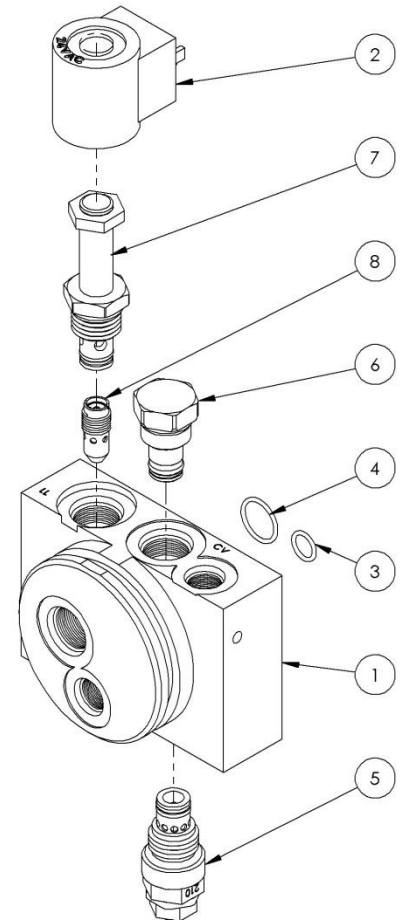

SOLENOID VALVE
99-153-015



Bleeding the hydraulic cylinder.

Air can enter the hydraulic system at any time its components are opened for service. Symptoms of air in the system include erratic or bouncing motion of the platform, sponginess in holding position, unusual noises, or foaming in the hydraulic fluid. Trapped air can also trigger the cylinder's velocity fuse, slowing or preventing the cylinder from lowering.

Cycling the platform up and down without a load can expel much of the trapped air through the hydraulic reservoir.

TROUBLESHOOTING GUIDE



WARNING

Care should be taken to identify all potential hazards and comply with applicable safety procedures before beginning work.



WARNING

Remove any load and install the maintenance props before beginning any inspection or service on the lift table. See below.

Only qualified individuals trained to understand mechanical devices, electrical and hydraulic circuits, and the hazards associated with them, should attempt troubleshooting and repair of this equipment.

Consult the factory for any problems not addressed in this manual. ALWAYS have the product serial number or model number on hand when calling the factory.

PROBLEM	POSSIBLE CAUSES	ACTION
Power unit doesn't run when "UP" button is pressed.	Transformer fuse is blown or circuit breaker tripped.	Test with meter. Replace if bad. Check electric circuit for source of fault.
	No supply voltage.	Test with meter. Check fuses, breakers, and overloads to determine the cause
	Upper-travel limit switch is engaged or bad.	Inspect and test switch. Replace if bad.
	Bad control transformer.	Check for 24 VAC at secondary. Replace if bad.
	Bad motor relay coil.	Test with meter. Replace if bad.
Motor runs but platform doesn't move. Power unit not noisy.	Motor rotation is wrong (3Ø).	Verify the motor runs CW, opposite the shaft end.
	Fluid level in reservoir is low.	Add fluid. Fluid should be 1" to 1-½" below the reservoir fill hole with the platform in the fully lowered position.
	Pump is failing to produce pressure.	Consult factory.

PROBLEM	POSSIBLE CAUSES	ACTION
Motor hums or pump squeals, but the platform does not move, or the platform moves only slowly.	Pump is failing to produce pressure.	Consult factory.
	Excess voltage drop to motor, due to power wire size too small, wire run too long, or incoming voltage too low.	Check the power installation for adequacy. Check the incoming voltage <i>while the motor is running</i> . Correct any problems found.
	Motor is "single-phasing".	Determine and correct cause of voltage loss on phase.
	Pressure relief opening at full pressure.	Check for structural damage or binding of the scissor legs, etc. Check for platform overload condition.
	Contamination holding open the lowering valve or the check valve.	Remove and inspect valves. Clean per instructions in the "Inspection and Maintenance" section.
Platform raises, then drifts down.	Contamination holding open the lowering valve or the check valve.	Remove and inspect valves. Clean per instructions in "Inspection and Maintenance" section.
Spongy or jerky platform movement.	Excessive air in the hydraulic cylinders.	Cycle the platform up and down several times, without load, to expel air from system.
	Fluid level in reservoir is low.	Add fluid. Fluid should be 1" to 1-½" below the reservoir fill hole with the platform in the fully lowered position.
Platform won't lower.	Perimeter toe guard actuated.	Check for a toe guard extrusion or rubber corner that is stuck. Adjust if necessary.
	Perimeter toe guard switch or wire broken.	Inspect visually; check with multimeter. Repair as needed.
	Solenoid coil is bad.	Check with multimeter using the diode-check function. (Reading for ohms will not provide an accurate test of the coil). Replace if bad.
	Physical blockage of the mechanism.	Inspect for foreign material or objects blocking the scissors or the rollers.
	Solenoid valve, flow control, or suction hose screen plugged.	Remove and inspect valves. Clean per instructions in "Inspection and Maintenance" section.
Platform lowers too slowly.	Solenoid valve, flow control, or suction hose screen plugged.	Remove and inspect valves. Clean per instructions in "Inspection and Maintenance" section.
	Velocity fuse locking (indicated by platform only slowly creeping down).	Check for air in hydraulic system. Cycle the platform up and down several times, without load, to expel air from system.
	Flow control valve spool sticking.	Remove and inspect valves. Clean per instructions in "Inspection and Maintenance" section.
Platform lowers too quickly.	Flow control valve spool sticking.	Remove and inspect valves. Clean per instructions in "Inspection and Maintenance" section.

LABELING DIAGRAM

The lift table should be labeled as shown in the diagrams. However, label content and location are subject to change so your product might not be labeled exactly as shown. Thoroughly photograph the lift table when you first receive it as discussed in the Record of Satisfactory Condition section on p. 24. Make sure that your record includes a photograph of each label. Replace all labels that are or later become damaged, missing, or not easily readable (e.g. faded).

To order replacement labels, contact the technical service and parts department online at http://www.vestilmfg.com/parts_info.htm. Alternatively, you may request replacement parts and/or service by calling (260) 665-7586 and asking the operator to connect you to the Parts Department.

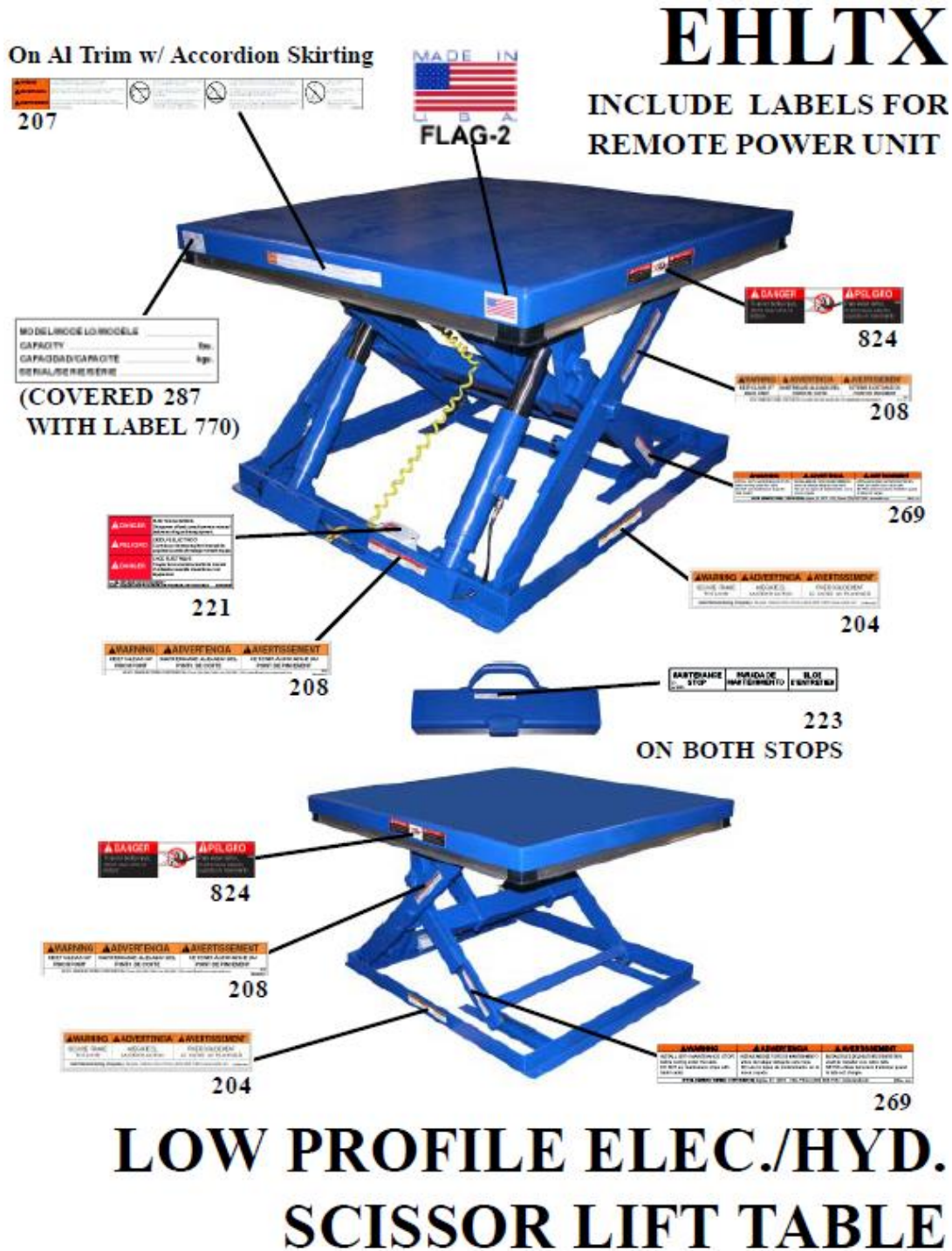

LIMITED WARRANTY

Vestil Manufacturing Corporation ("Vestil") warrants this product to be free of defects in material and workmanship during the warranty period. Our warranty obligation is to provide a replacement for a defective, original part covered by the warranty after we receive a proper request from the Warrantee (you) for warranty service.

Who may request service?

Only a warrantee may request service. You are a warrantee if you purchased the product from Vestil or from an authorized distributor AND Vestil has been fully paid.

Definition of "original part"?

An original part is a part used to make the product as shipped to the Warrantee.

What is a "proper request"?

A request for warranty service is proper if Vestil receives: 1) a photocopy of the Customer Invoice that displays the shipping date; AND 2) a written request for warranty service including your name and phone number. Send requests by one of the following methods:

US Mail

Vestil Manufacturing Corporation
2999 North Wayne Street, PO Box 507
Angola, IN 46703

Fax

(260) 665-1339
Phone
(260) 665-7586

Email

info@vestil.com

Enter "Warranty service request" in subject field

In the written request, list the parts believed to be defective and include the address where replacements should be delivered. After Vestil receives your request for warranty service, an authorized representative will contact you to determine whether your claim is covered by the warranty. Before providing warranty service, Vestil will require you to send the entire product, or just the defective part (or parts), to its facility in Angola, IN.

What is covered under the warranty?

The warranty covers defects in the following original, dynamic parts: motors, hydraulic pumps, motor controllers, and cylinders. It also covers defects in original parts that wear under normal usage conditions ("wearing parts"), such as bearings, hoses, wheels, seals, brushes, and batteries.

How long is the warranty period?

The warranty period for original dynamic components is 1 year. For wearing parts, the warranty period is 90 days. Both warranty periods begin on the date Vestil ships the product to the Warrantee. If the product was purchased from an authorized distributor, the periods begin when the distributor ships the product. Vestil may, at its sole discretion, extend a warranty period for products shipped from authorized distributors by up to 30 days to account for shipping time.

If a defective part is covered by the warranty, what will Vestil do to correct the problem?

Vestil will provide an appropriate replacement for any covered part. An authorized representative of Vestil will contact you to discuss your claim.

What is not covered by the warranty?

The Warrantee (you) are responsible for paying labor costs and freight costs to return the product to Vestil for warranty service.

Events that automatically void this Limited Warranty.

- Misuse;
- Negligent assembly, installation, operation or repair;
- Installation/use in corrosive environments;
- Inadequate or improper maintenance;
- Damage sustained during shipping;
- Collisions or other accidents that damage the product;
- Unapproved modifications: Do not modify the product IN ANY WAY without first receiving written authorization from Vestil.

Do any other warranties apply to the product?

Vestil Manufacturing Corp. makes no other express warranties. All implied warranties are disclaimed to the extent allowed by law. Any implied warranty not disclaimed is limited in scope to the terms of this Limited Warranty. Vestil makes no warranty or representation that this product complies with any state or local design, performance, or safety code or standard. Noncompliance with any such code or standard is not a defect in material or workmanship.

